

Enjoy Clean, Quiet, and Comfortable Air Conditioning with LG



Making you and your environment more comfortable

LG has a comprehensive range of air conditioning solutions designed to suit a wide range of buildings or spaces.



USER FRIENDLY CONTROL

LG's air conditioning solution allows users to take advantage of a hassle-free, intuitive management system via the controller

EASY INSTALLATION & MAINTENANCE

The built-in evaporator safety tray makes the product much easier to install and maintain. Must be installed by a licensed installer system via the controller



HIGH RELIABILITY & COMFORT

LG's latest technological innovations ensure greater overall system reliability as well as convenient benefits such as quick, stable cooling and a wider operation range than conventional systems.



SMART APPLICATION

Easily access and control your Air Conditioner from your smart phone.

* Wireless home network required



ENERGY EFFICIENT

The revolutionary inverter technology of LG boasts powerful yet quiet performance while minimising energy consumption.

Energy Efficient



▶ POWERFUL BLDC COMPRESSOR

LG air conditioner comes with a BLDC compressor that uses a strong neodymium magnet. Its compressor thus has improved efficiency compared with conventional AC inverters. Operation range has been expanded.



● **BLDC**
Concentrated Winding

Operation Frequency

15 ~ 100 Hz



● **Conventional**
Distributed Winding

20 ~ 100 Hz

▶ BLDC FAN MOTOR TECHNOLOGY

The LG BLDC fan motor offers additional efficiency in operating mode up to 40% at low speed, 20% at high speed compared to a LG AC motor



BLDC Fan Motor

- 1 Heat Exchanger
- 2 BLDC Fan Motor Technology
- 3 Powerful BLDC Compressor

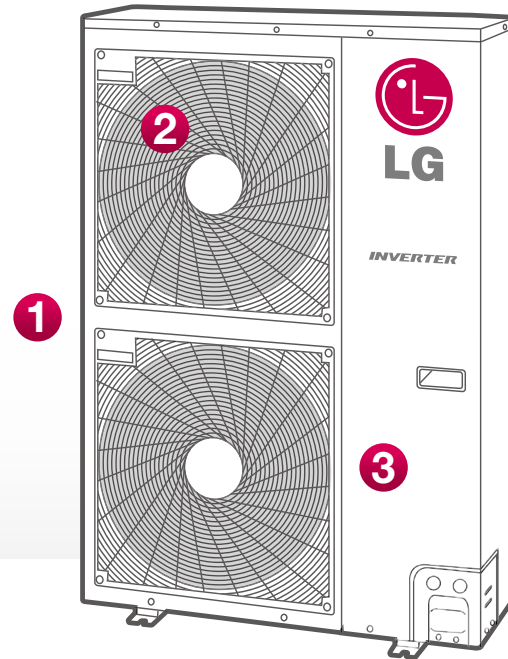

HEAT EXCHANGER WITH WIDE LOUVER FIN

Improved heat exchanger efficiency up to *28%, applying Multi V technology.

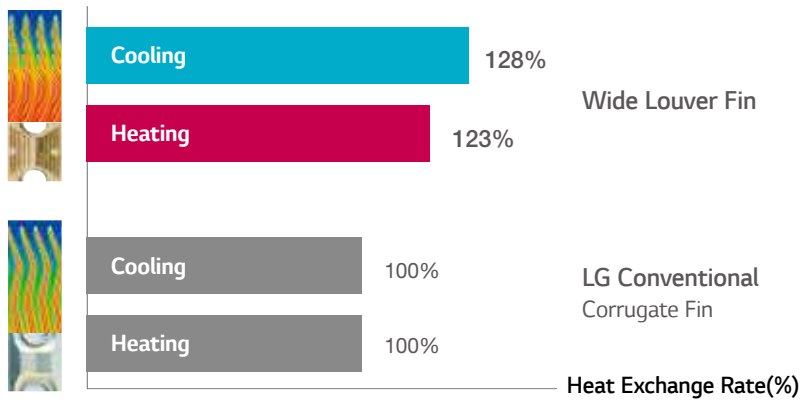

* Compared to our previous Inverter design.

OPTIMISED HEAT EXCHANGER PATH

Improved Refrigerant cycle efficiency up to 5% with equal distribution.

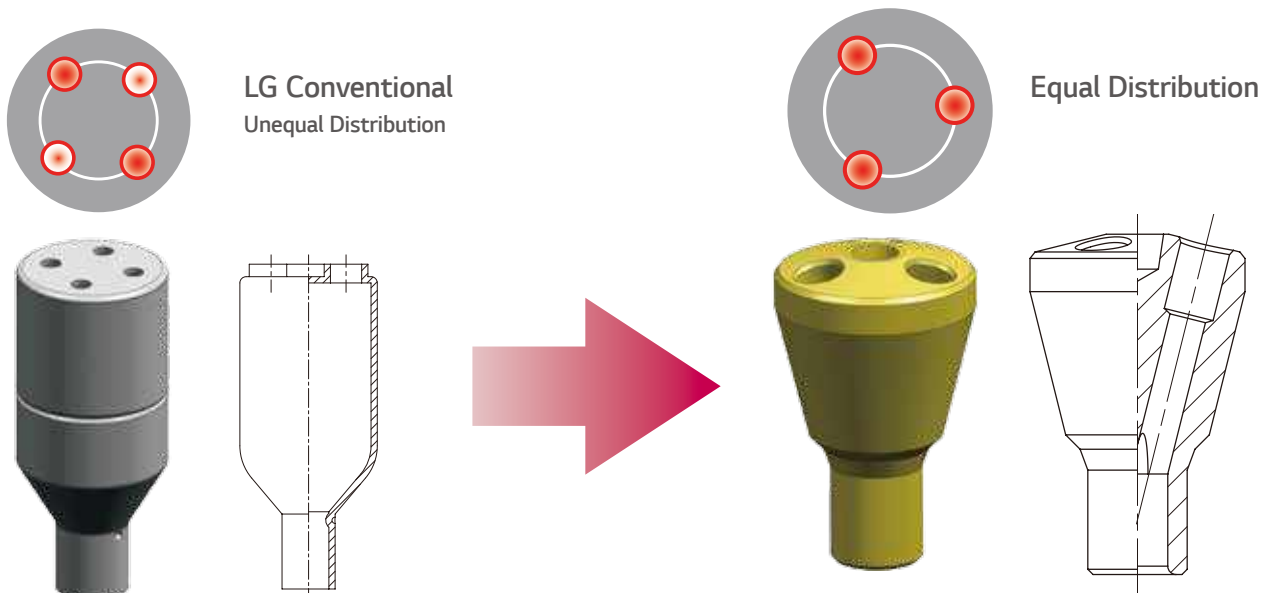

USER FRIENDLY WALL CONTROLLER

Three optional wall controllers are available:

1. Premium wall controller -
2. Deluxe wall controller -
3. Standard wall controller -

▶ CONTROLLER

• Premium Controller (optional)



PREMTA000

User Friendly Design

Premium design with intuitive GUI and Standard & Simple modes allows for quick and easy control of various functions and settings for up to 16 indoor units

Advanced Schedule Functions

Convenient schedule functions allow for the control of weekly, monthly and yearly time periods as well as effective management of seasonal cycles.

Intelligent Energy Management

Energy monitoring and operational run time control including temperature lock function. Graphical representation of energy usage, target energy consumption, operation time limit and alarm pop up.

• Deluxe Wall Controller (optional)

LCD Backlit Display

Touch Screen Panel

8 Zone Control



PDRUCDCO

• Standard (WIDE) Wall Controller (optional)

The operator can set the timing function of the air conditioner for a period of one week.



PQRCVSLOQW

LCD backlit display



Enables you to easily see the control settings.

► DUAL THERMISTORS CONTROL

Dual thermistor control provides the option to control temperature by referring to either of the dual temperature sensors. With the help of the slide switch at the back of the LCD wired remote controller, selection of the desired thermistor for controlling the unit can be achieved. One thermistor is in the Indoor unit & the other one is in the LCD wired remote.

Compares temperatures sensed from different positions and automatically selects the optimum temperature for users

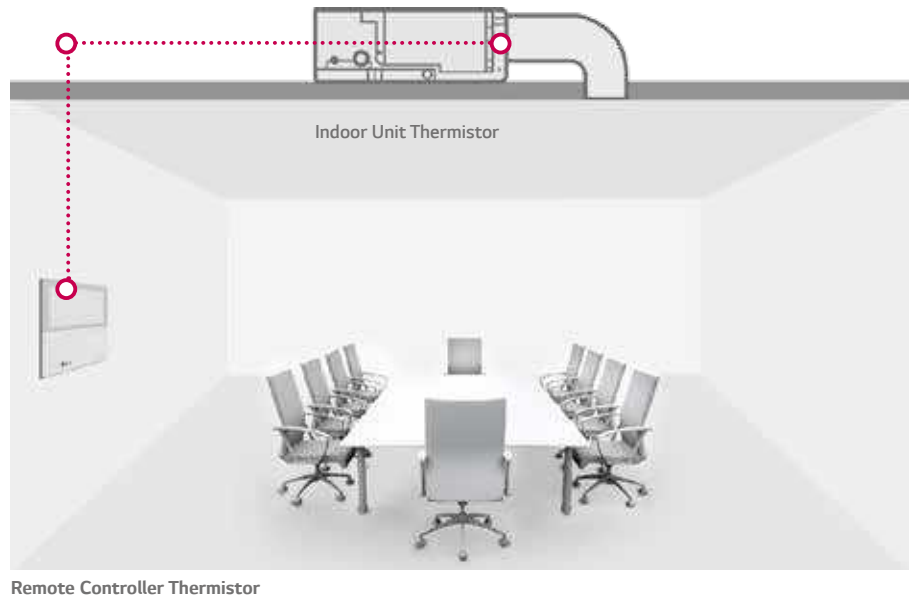

► OPERATION FOR MULTIPLE ROOMS

Using a duct (solid or flexible type), it is possible to operate cooling / heating for several rooms simultaneously.

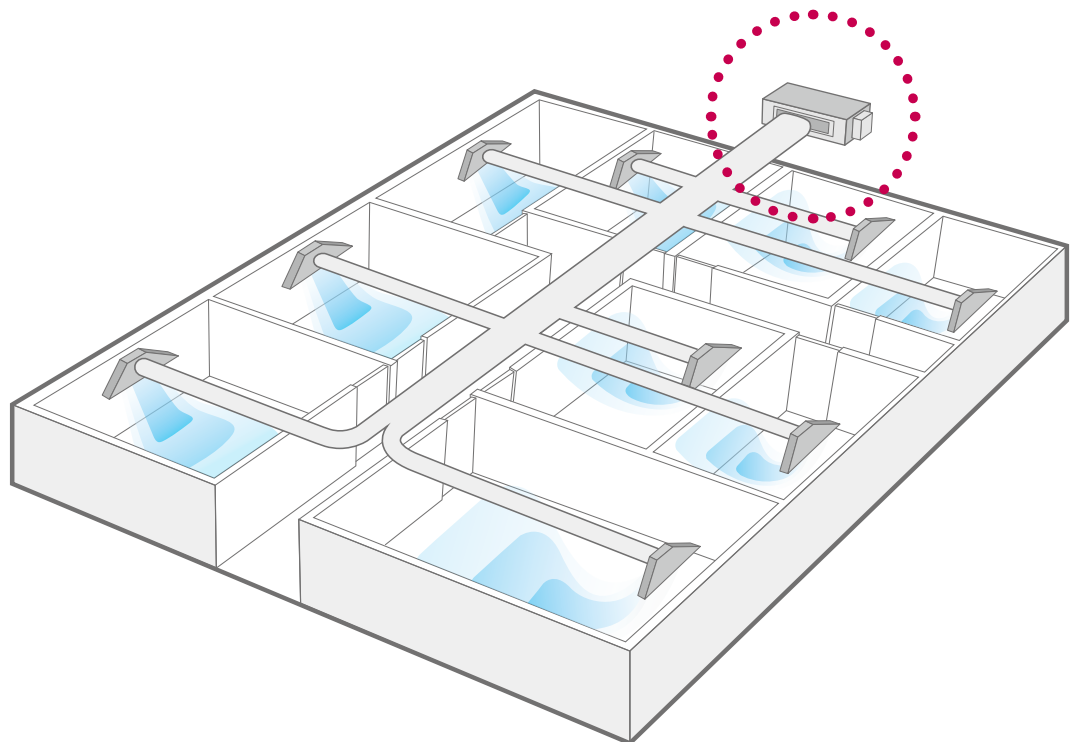

EASY INSTALLATION & MAINTENANCE

▶ EASY SERVICE & MAINTENANCE

There is now a separate panel for the heat exchanger and fan/motor. Coupled with the fan/motor filter redesign for easy removal and installation, maintenance of the LG unit has been simplified even in limited spaces.

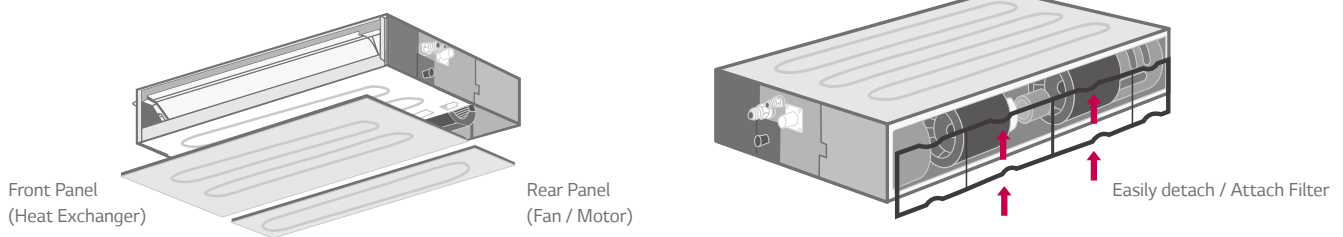

▶ SPLIT TYPE INDOOR UNIT

Fan/motor part assembly and heat exchanger assembly can be separated. This enables installation of the indoor unit in two parts before final assembly.

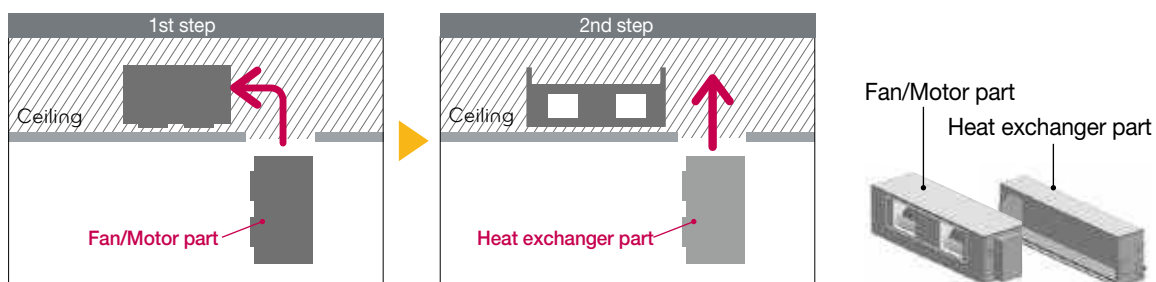

• This feature is ONLY available for B62, B70 unit.

▶ MINIMIZED HEIGHT

New mid-static ducts provide ideal solution for installation in limited space.

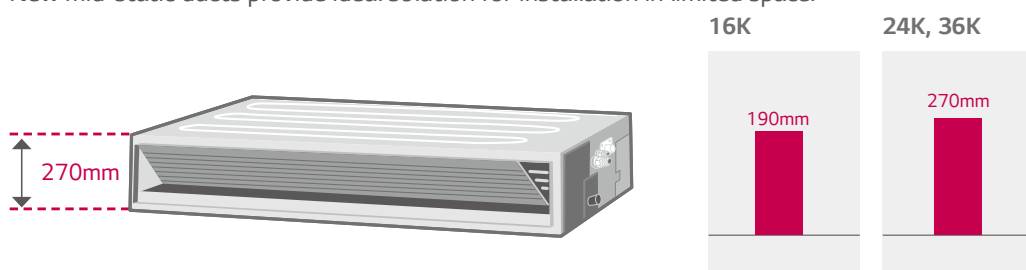

• This feature is ONLY available for Low, Mid Static Model.

▶ HIGH HEAD DRAIN PUMP

Auxiliary Drain Pump automatically drains water. A standard drain-head height of up to 800mm is possible, which helps create the ideal solution for water drainage.

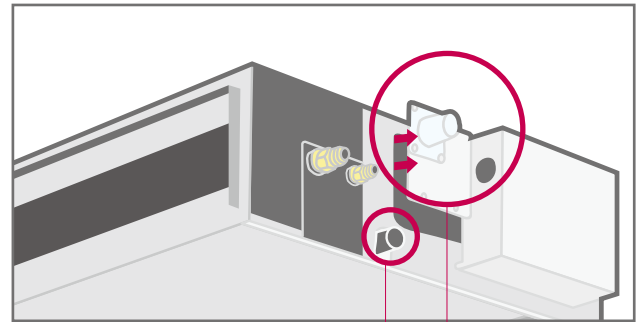
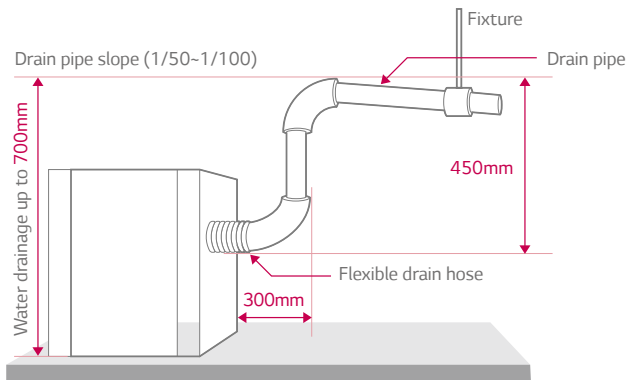

Available for natural drainage ○
Detachable drain pump ○

▶ FLEXIBLE INSTALLATION (LOW STATIC DUCT ONLY)

The new low static duct allows the air intake to be positioned either at the rear or bottom during installation.

Conventional

Air intake at the only rear

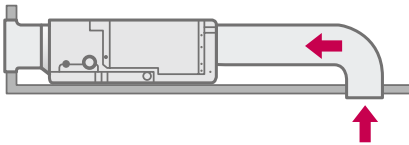

New Low Static Duct

Air intake at the rear or bottom

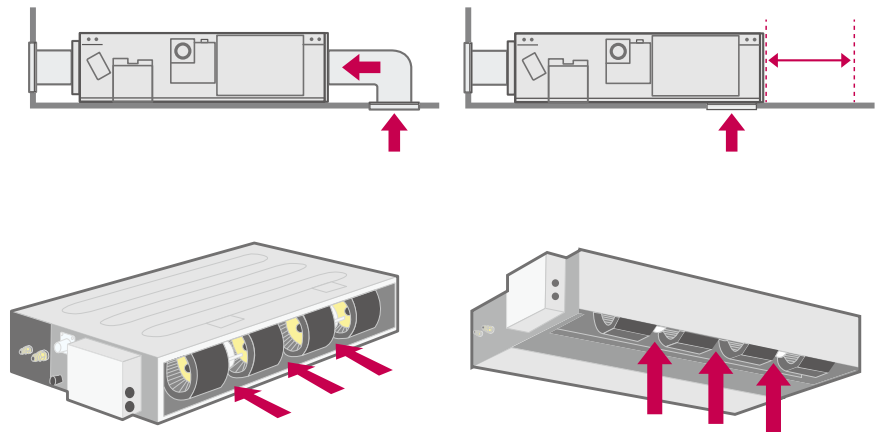

▶ COMPACT DESIGN

Compact IDU Size

Slim and Low height compact body could reduce problems during installation stage.

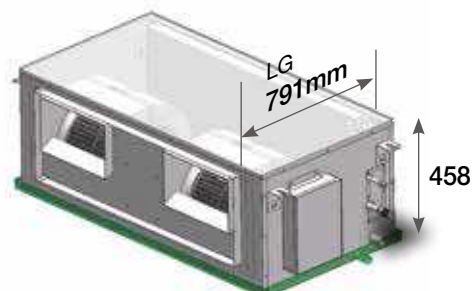

* For B70 indoor unit.



SMART APPLICATION (OPTIONAL)

The ducted split system can be controlled by your smart phone using the LG Smart AC app. You can control settings such as on-off, operation mode (cool, heat, auto and fan), set desired temperature and adjust fan speed with the purchase of the optional WLAN module.

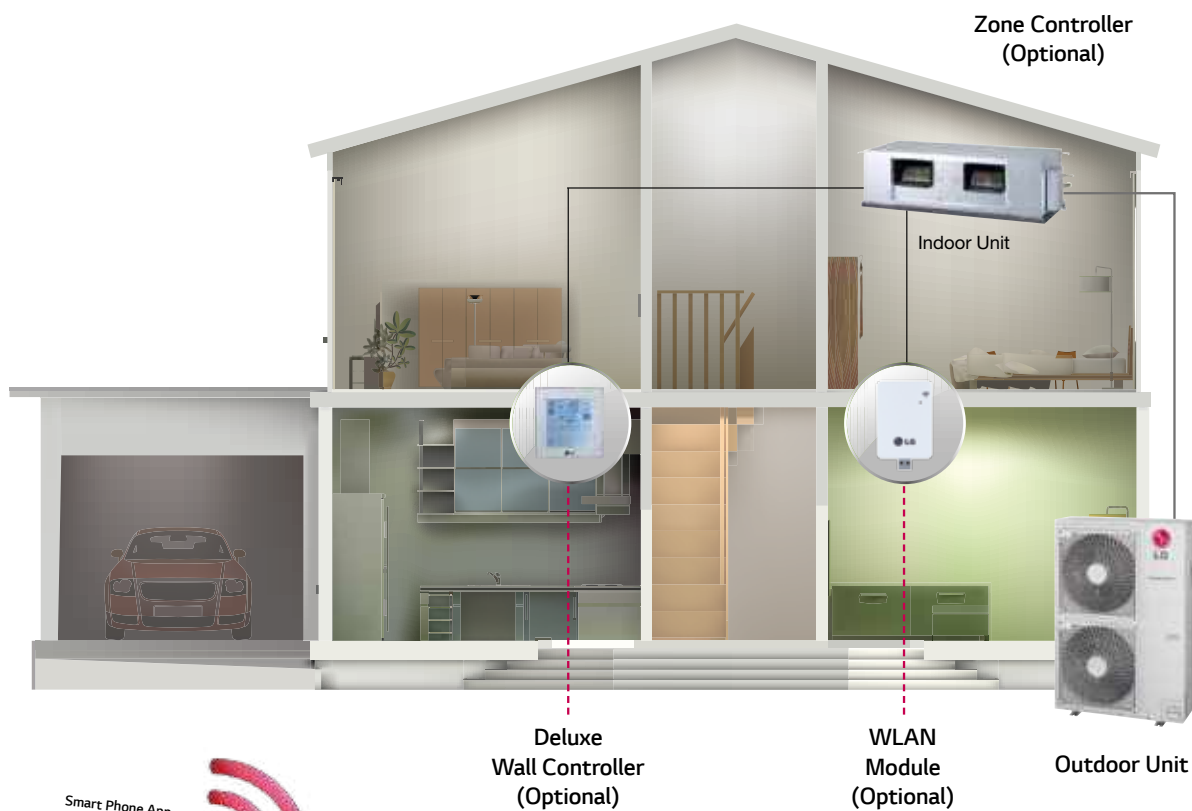

WLAN Module (Optional)



• Excludes B18-24-36 AWYNGMD

INVERTER

Slim / Low Static

B18AWYNGMD



B18AWYUGMD



Indoor				B18AWYNGMD	
Capacity	Cooling	Min/Rated/Max	kW	2.0 / 5.1 / 6.0	
	Heating	Min/Rated/Max	kW	2.2 / 6.0 / 7.3	
Power Input	Cooling	Rated	kW	1.65	
	Heating	Rated	kW	1.82	
Running Current	Cooling/Heating	Rated	A	7.2/7.9	
Power Supply			V/ø/Hz	220-240 / 1 / 50	
EER				3.09	
COP				3.30	
Piping Connection	Liquid		mm	Ø 6.35	
	Gas		mm	Ø 12.7	
	Drain	O.D./I.D.	mm	Ø 32 / 25	
Air Flow Rate		High/Medium/Low	m ³ /min	15.0 / 12.5 / 10.0	
			l/s	250 / 208 / 166	
Sound Pressure	Cooling	High/Medium/Low	dBA	36 / 34 / 31	
	Heating	High/Medium/Low	dBA	36 / 34 / 31	
Sound Power	Cooling	Max	dBA	54	
Dehumidification Rate			l/h	1.7	
Dimensions	Body	WxHxD	mm	900 × 190 × 700	
Net Weight	Body		kg	23.0 (50.7)	
Supply Air Spigot		WxH	mm	860 × 148	
Return Air Spigot		WxH	mm	860 × 155	
Fan Motor Output			W	85.4 × 1	
External Static Pressure -pre set		Min-Max	Pa	24.5 (2.5)	
Outdoor				B18AWYNGMD	
Compressor	Type			Twin Rotary	
Airflow Rate		Rated	m ³ /min	50 × 1	
			l/s	833 × 1	
Sound Pressure	Cooling	Rated	dBA	48	
	Heating	Rated	dBA	51	
Sound Power	Cooling	Max	dBA	60	
Dimensions	WxHxD		mm	870 × 655 × 320	
Net Weight			kg	46	
Refrigerant	Type			R410A	
	Charge		g	1,400	
	Chargeless Piping Length (after 7.5m)		m	20	
Operation Range (Outdoor)	Cooling	Min-Max	°C DB	(-)15 ~ 48	
	Heating	Min-Max	°C WB	(-)18 ~ 18	
Power Supply			V/ø/Hz	220-240 / 1 / 50	
Power Supply Cable			N x mm ²	3C x 2.5	
Transmission Cable			N x mm ²	4C x 0.75	
Circuit Breaker			A	20	
Piping Length Total		Max	m	40	
Piping Elevation Difference	IDU-ODU	Max	m	30	
Piping Connection	Liquid		mm	Ø 6.35	
	Gas		mm	Ø 12.7	

Note : 1. Due to our policy of innovation some specifications may be changed without notification.

2. Capacities are based on the in accordance with AS/NZS3823.1.2

Cooling: - Indoor Temperature 27°C DB / 19°C WB Heating: - Indoor Temperature 20°C DB / 15°C WB
- Outdoor Temperature 35°C DB / 24°C WB - Outdoor Temperature 7°C DB / 6°C WB

INVERTER

B24AWYNGMD B36AWYNGMD



Slim / Mid Static



B24AWYNGMD



B36AWYNGMD



Indoor				B24AWYNGMD	B36AWYNGMD
Capacity	Cooling	Min/Rated/Max	kW	2.8 / 7.1 / 7.8	4.0 / 10.0 / 11.0
	Heating	Min/Rated/Max	kW	3.2 / 8.1 / 8.8	4.5 / 11.2 / 12.3
Power Input	Cooling	Rated	kW	2.03	3.24
	Heating	Rated	kW	2.23	3.36
Running Current	Cooling/Heating	Rated	A	8.8/9.7	14.1/14.6
Power Supply			V/ø/Hz	220-240 / 1 / 50	220-240 / 1 / 50
EER				3.57	3.09
COP				3.54	3.33
Piping Connection	Liquid		mm	Ø 9.52	Ø 9.52
	Gas		mm	Ø 15.88	Ø 15.88
	Drain	O.D./I.D.	mm	Ø 32 / 25	Ø 32 / 25
Air Flow Rate		High/Medium/Low	m ³ /min	22.0 / 20.0 / 18.0	32.0 / 28.0 / 24.0
			l/s	366 / 333 / 300	533 / 466 / 400
Sound Pressure	Cooling	High/Medium/Low	dB(A)	37 / 35 / 34	36 / 34 / 33
	Heating	High/Medium/Low	dB(A)	37 / 35 / 34	36 / 34 / 33
Sound Power	Cooling	Max	dB(A)	62	60
Dehumidification Rate			l/h	2.8	3.2
Dimensions	Body	WxHxD	mm	900 x 270 x 700	1,250 x 270 x 700
Net Weight	Body		kg	25.3 (55.8)	36.0 (79.4)
Supply Air Spigot		WxH	mm	857 x 200	857 x 200
Return Air Spigot		WxH	mm	850 x 231	850 x 231
Fan Motor Output			W	136.5 x 1	295 x 1
External Static Pressure -pre set		Min-Max	Pa	58.8 (6)	58.8 (6)
Outdoor				B24AWYUGMD	B36AWYUGMD
Compressor	Type			Twin Rotary	Twin Rotary
Airflow Rate	Rated		m ³ /min	58 x 1	45 x 2
			l/s	1966	750 x 2
Sound Pressure	Cooling	Rated	dB(A)	48	53
	Heating	Rated	dB(A)	52	54
Sound Power	Cooling	Max	dB(A)	62	66
Dimensions	WxHxD		mm	950 x 834 x 330	950 x 1,170 x 330
Net Weight			kg	60	81
Refrigerant	Type			R410A	R410A
	Charge		g	2,000	2,800
	Chargeless Piping Length (after 7.5m)		m	40	40
Operation Range (Outdoor)	Cooling	Min-Max	°C DB	(-)15 ~ 48	(-)15 ~ 48
	Heating	Min-Max	°C WB	(-)18 ~ 18	(-)18 ~ 18
Power Supply			V/ø/Hz	220-240 / 1 / 50	220-240 / 1 / 50
Power Supply Cable			N x mm ²	3C x 2.5	3C x 5.0
Transmission Cable			N x mm ²	4C x 0.75	4C x 0.75
Circuit Breaker			A	30	40
Piping Length Total		Max	m	50	50
Piping Elevation Difference	IDU-ODU	Max	m	30	30
Piping Connection	Liquid		mm	Ø 9.52	Ø 9.52
	Gas		mm	Ø 15.88	Ø 15.88

Note : 1. Due to our policy of innovation some specifications may be changed without notification.

2. Capacities are based on the in accordance with AS/NZS3823.1.2

Cooling: - Indoor Temperature 27°C DB / 19°C WB Heating: - Indoor Temperature 20°C DB / 15°C WB
- Outdoor Temperature 35°C DB / 24°C WB - Outdoor Temperature 7°C DB / 6°C WB